

Garage Framing Instructions

Planning & Installation

Roll-A-Door™

Note: Reduction of clear drive through opening height when door is fully open. With ongoing product developments, the manufacturers retain the right to change products and specifications without prior notification. If a specification is critical to the end use, please contact the manufacturer first.

Series 1

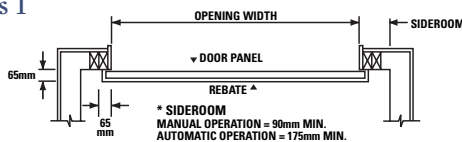

NOTE: For Automatic operation a power point on wall within 1.0m of the unit is required

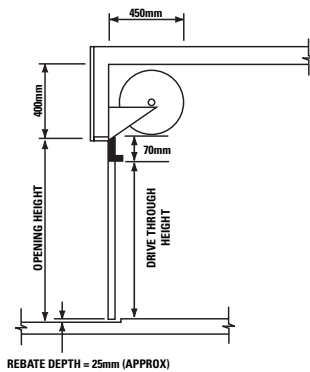

Series 3

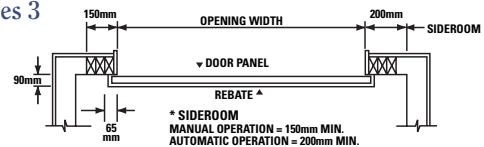

NOTE: For Automatic operation a power point on wall within 1.0m of the unit is required

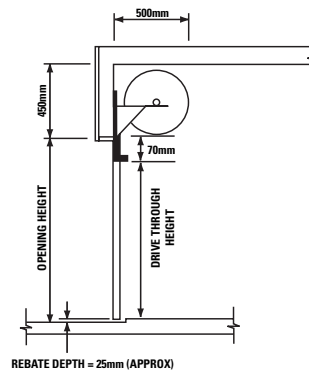

Tilt-A-Door™

With ongoing product developments, the manufacturers retain the right to change products and specifications without prior notification. If a specification is critical to the end use, please contact the manufacturer first.

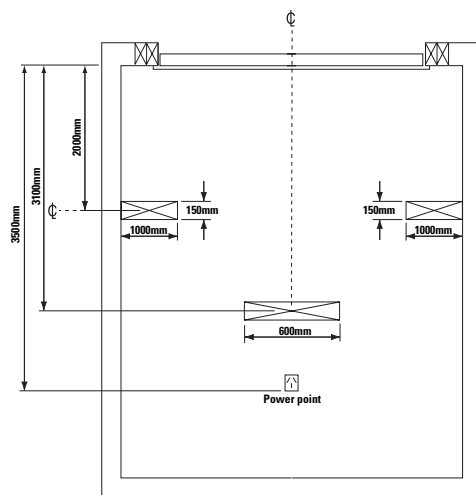
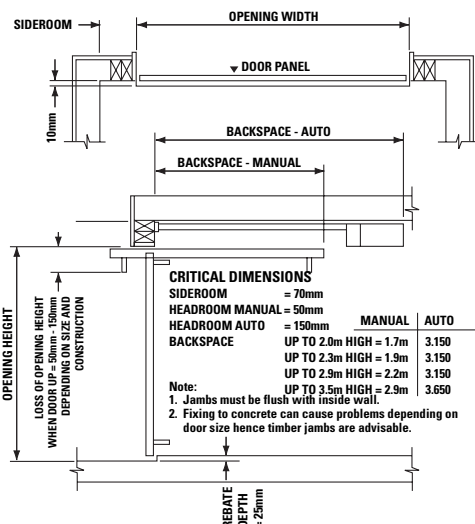

Sectional Panelift™

Note: With ongoing product developments, the manufacturers retain the right to change products and specifications without prior notification. If a specification is critical to the end use, please contact the manufacturer first.

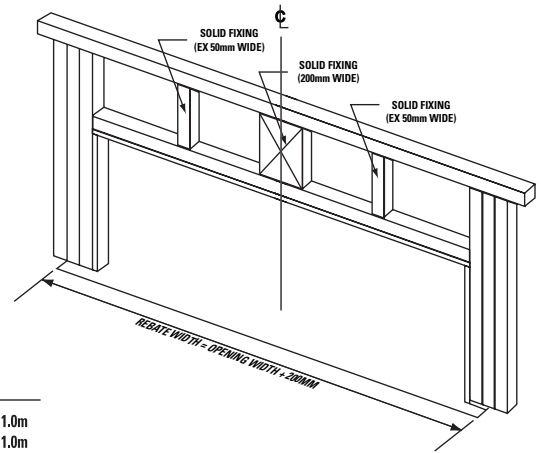
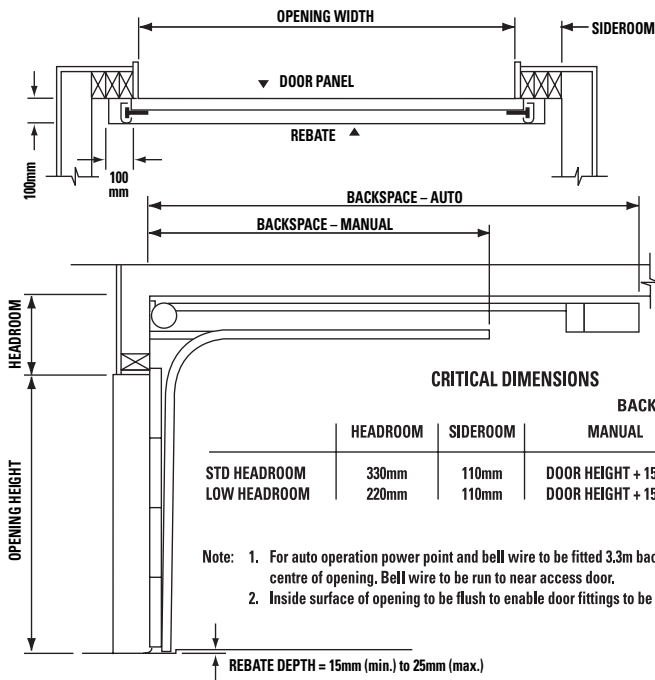

NOGGING DETAIL FOR SECTIONAL UP TO 2.3M HIGH (TRACK AND MOTOR FIXINGS)

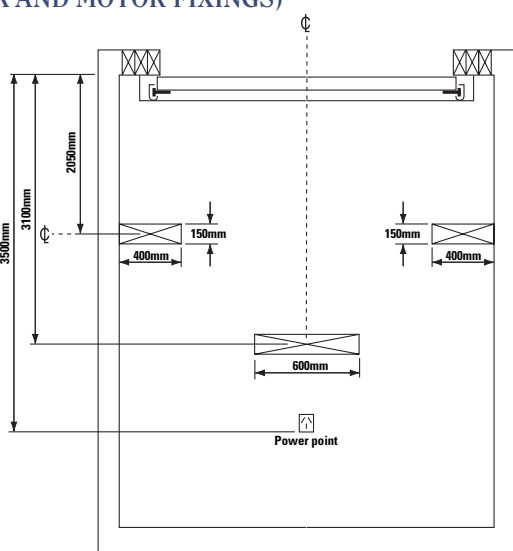

Note: The details shown are for 2.3m Maximum height Sectional Door with Standard 330mm Headroom. Also for Intermediate Headroom of 220mm with springing to front.

NOGGING DETAIL FOR SECTIONAL 2.35 – 3.35M HIGH (TRACK AND MOTOR FIXINGS)

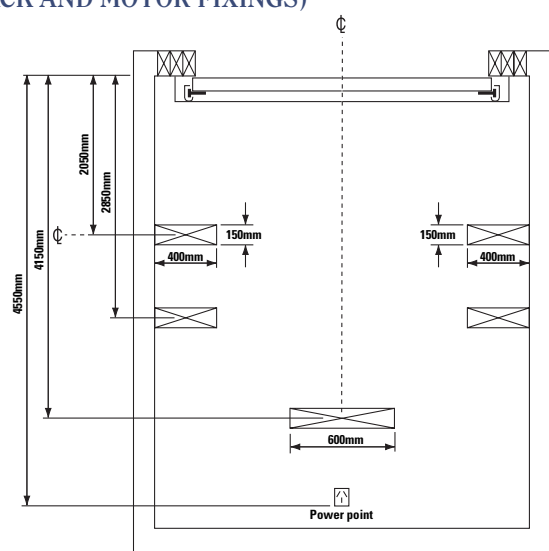

Note: The details shown are for 3.35m Maximum height Sectional Door with Standard 330mm Headroom. Also for Intermediate Headroom of 220mm with springing to front. Measurements for motor with 2.3m C-Rail and 1m extension.



Notes / Information

- a) The company reserves the right to make changes or improvements to the products or accessories without further notice and without incurring any obligation to make similar changes or improvements to goods previously ordered. Specifications subject to change without notice.
 - b) Prefixed Trademarks are trademarks of B&D Doors (NZ) Ltd.
 - c) Details correct at date of publication.
- Garador is a brand of B&D doors (NZ) Ltd, an Alesco company. © Copyright 2008.

Your Garador™ Dealer:

For more information on this product or others in our range, phone 0800 GARADOR or visit www.garador.co.nz