

Sectional Door Framing Instructions

For Sectional Doors Up To 2.30m High

Note: With ongoing product developments, the manufacturer retains the right to change products & specifications without notification. If a specification is critical to the end use, please discuss with your Local Dealer first. Illustrations are not accurate representations of product, and are for illustrative purposes only, not to scale. All measurements should be made by your Local Dealer for clarification.

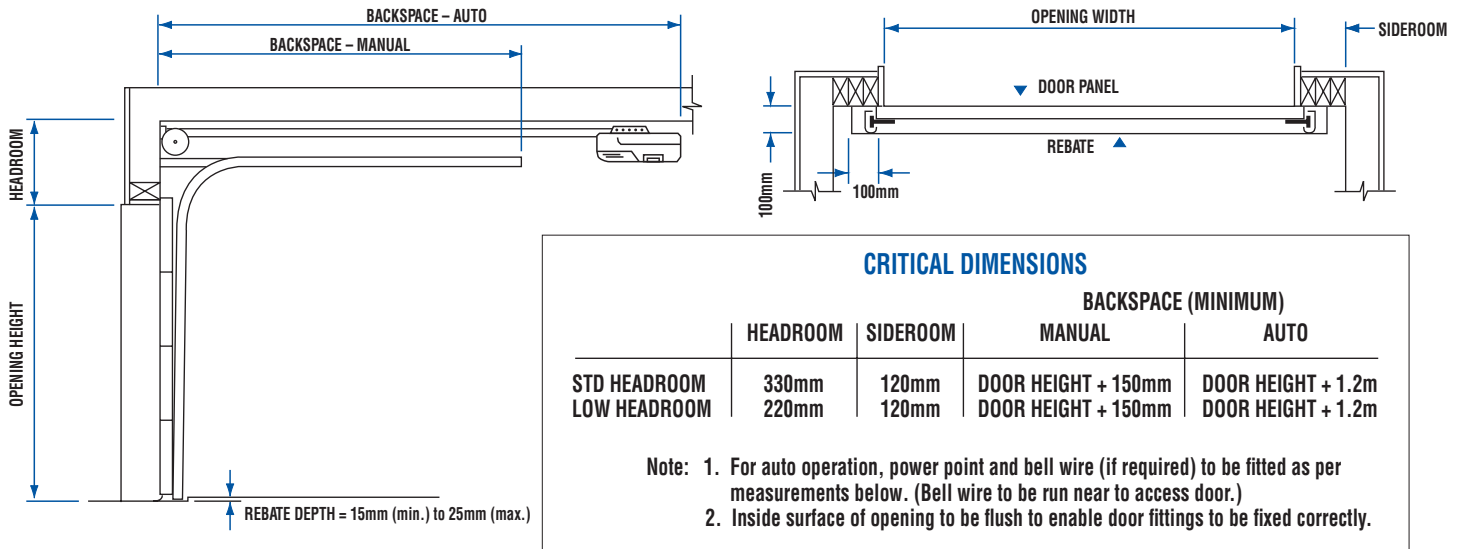

NOGGING DETAIL FOR SECTIONAL UP TO 2.3M HIGH (TRACK AND MOTOR FIXINGS)

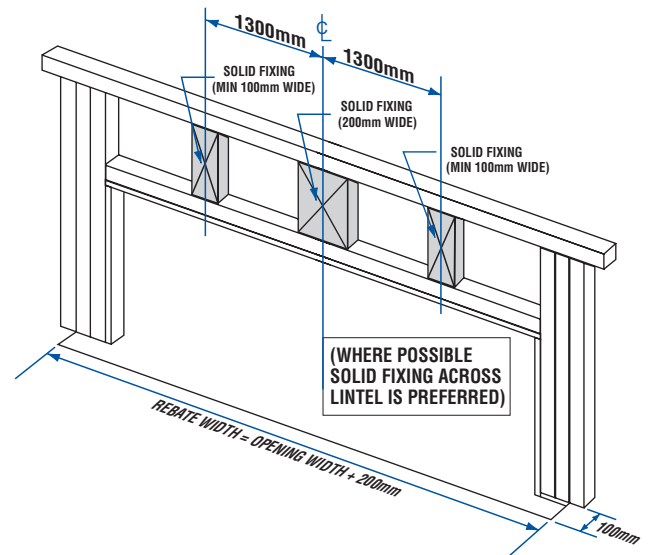
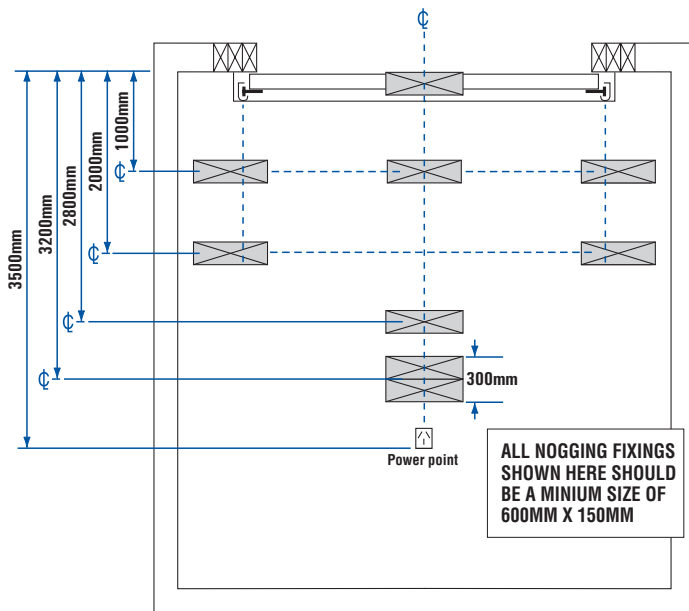

Note: The details shown are for 2.30m Maximum Height Sectional Door with Standard 330mm Headroom. Also for Intermediate Headroom of 220mm with springing to front.

Sectional Door Framing Instructions

For Sectional Doors 2.31 To 3.15m High

Note: With ongoing product developments, the manufacturer retains the right to change products & specifications without notification. If a specification is critical to the end use, please discuss with your Local Dealer first. Illustrations are not accurate representations of product, and are for illustrative purposes only, not to scale. All measurements should be made by your Local Dealer for clarification.

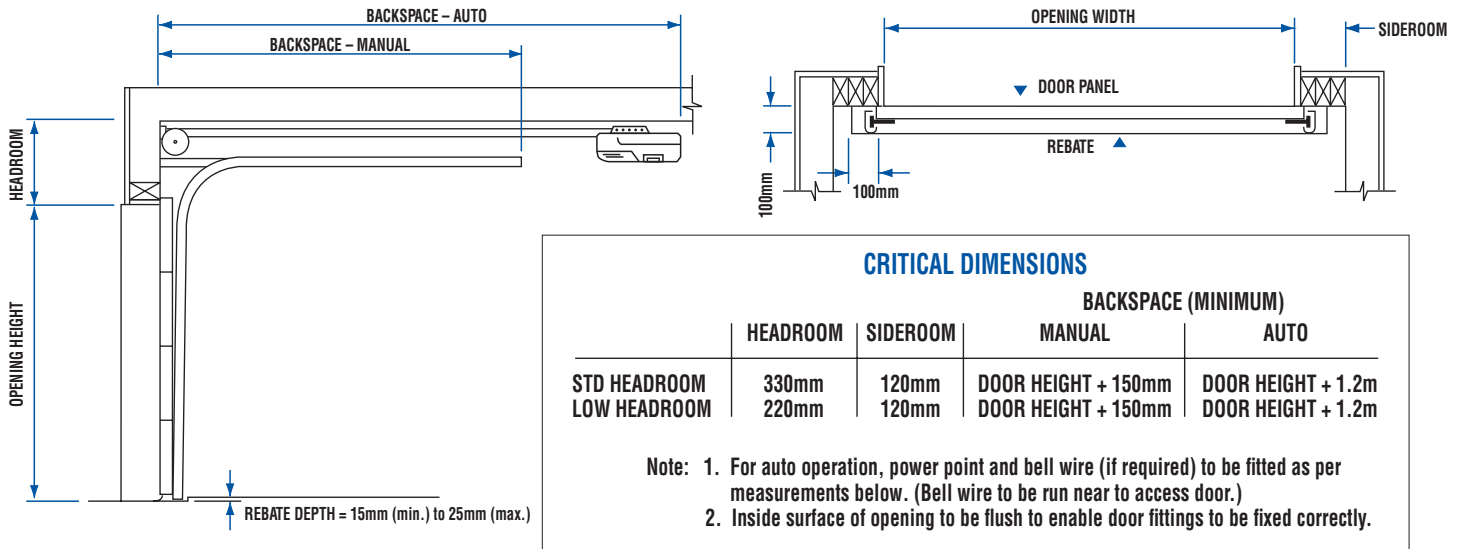

NOGGING DETAIL FOR SECTIONAL 2.31 - 3.15M HIGH (TRACK AND MOTOR FIXINGS)

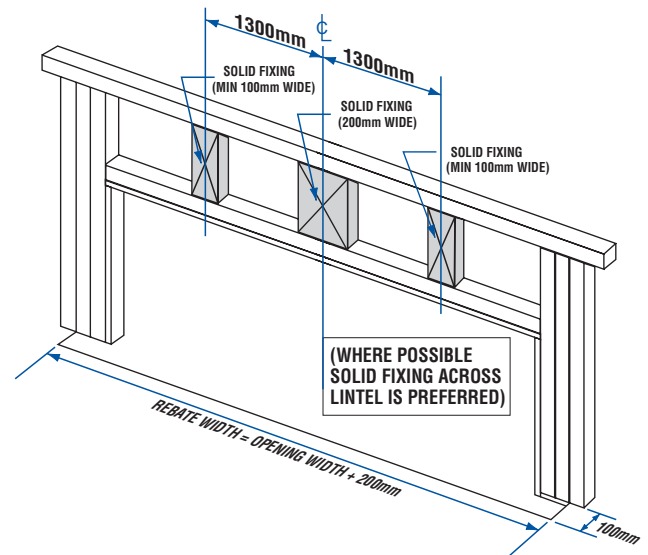
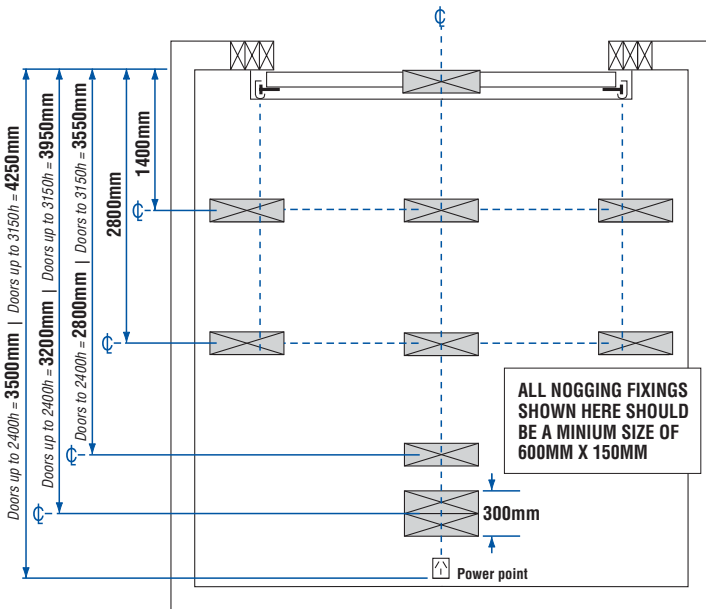

Note: The details shown are for 3.15m Maximum Height Sectional Door with Standard 330mm Headroom. Also for Intermediate Headroom of 220mm with springing to front. Measurements for doors over 2.40m high allow for motor with 1x C-Rail extension.

0800 427 236
www.garador.co.nz

Contact:

Sectional Door Framing Instructions

For Sectional Doors 3.16 To 3.90m High

Note: With ongoing product developments, the manufacturer retains the right to change products & specifications without notification. If a specification is critical to the end use, please discuss with your Local Dealer first. Illustrations are not accurate representations of product, and are for illustrative purposes only, not to scale. All measurements should be made by your Local Dealer for clarification.

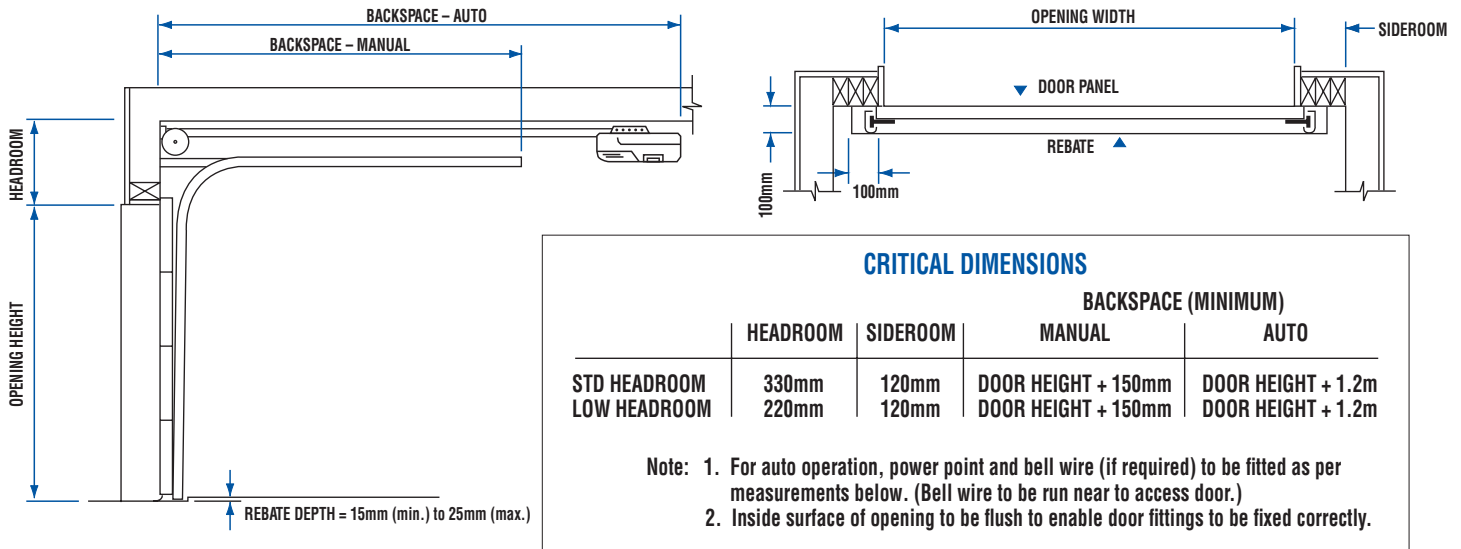

NOGGING DETAIL FOR SECTIONAL 3.16 - 3.90M HIGH (TRACK AND MOTOR FIXINGS)

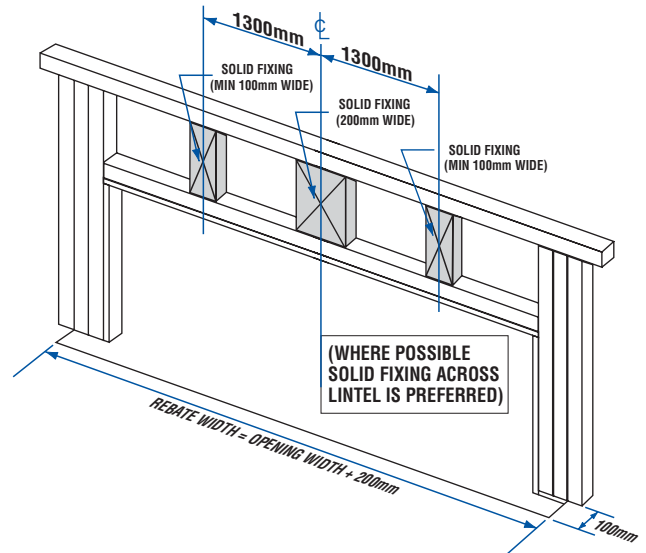
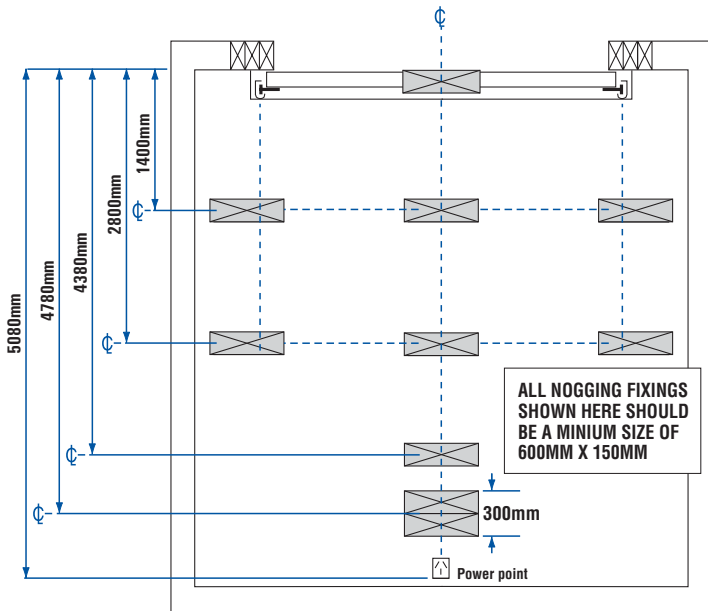

Note: The details shown are for 3.90m Maximum Height Sectional Door with Standard 330mm Headroom. Also for Intermediate Headroom of 220mm with springing to front. Measurements allow for motor with 2x C-Rail extensions.

0800 427 236
www.garador.co.nz

Contact: